

GR17016

Specifiche Tecniche

IP65 SCATOLA STAGNA DA PARETE 310X240X100

- REALIZZATO IN MATERIALE TECNOPOLIMERO ABS, DELLO SPESSORE CHE GARANTISCE MASSIMA ROBUSTEZZA E RESISTENZA IN OGNI PUNTO.
- TEMPERATURA D'INSTALLAZIONE -15 + 60°C
- RESISTENTE AL FUOCO FINO A 650 ° C GLOW WIRE TEST (CONFORMITÀ ALLA NORMA: EN60335-1: 94 + IEC 695-2-1)
- RESISTENZA AGLI URTI IK 08

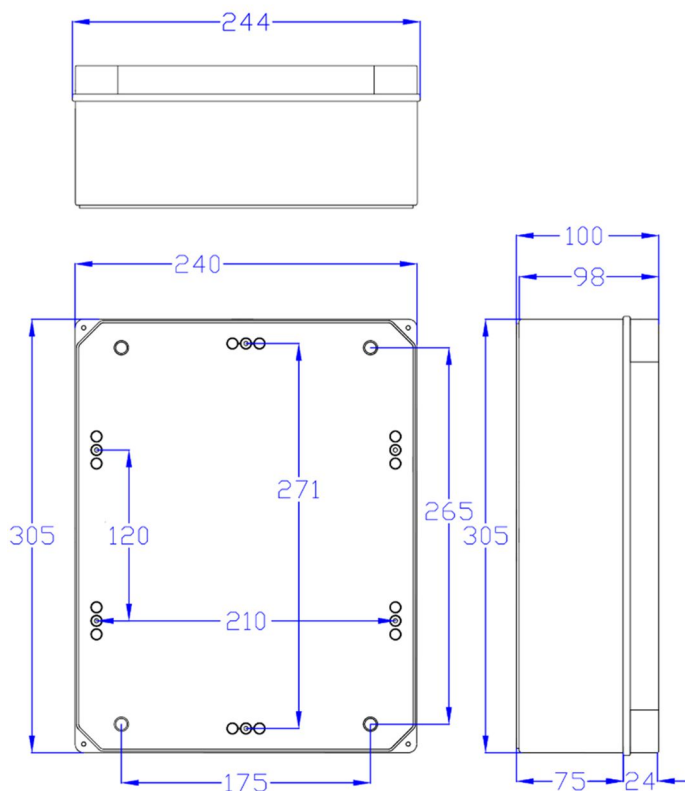

GR17016

Technical Specifications

IP65 BOX WITH SMOOTH WALLS 310X240X100

- MADE WITH THICK ABS TECHNOPOLYMER MATERIAL, ENSURING MAXIMUM STURDINESS AND STRENGTH
- WORKING TEMPERATURE $-15 + 60^{\circ}\text{C}$
- HEAT RESISTANT UP TO 650°C GLOW WIRE TEST (IN COMPLIANCE WITH STANDARDS: EN60335-1:94 + IEC 695-2-1)
- SHOCK RESISTENCE IK 08

